

Код F5086

## ELIZABETH WANDWASCHTISCHBATTERIE

- Nr. 2 Exzenteranschlüsse 1/2"
- drehbarer Auslauf

## Finishes

-  XPOM  
CR
-  BRUSHED NICKEL  
SN
-  ЗОЛОТО  
OR
-  OLD BRONZE  
BR
-  АНТИЧНАЯ МЕДЬ  
RA

## ИЗОБРАЖЕНИЕ



Общие условия продажи в нашем действующем прайс-листе.

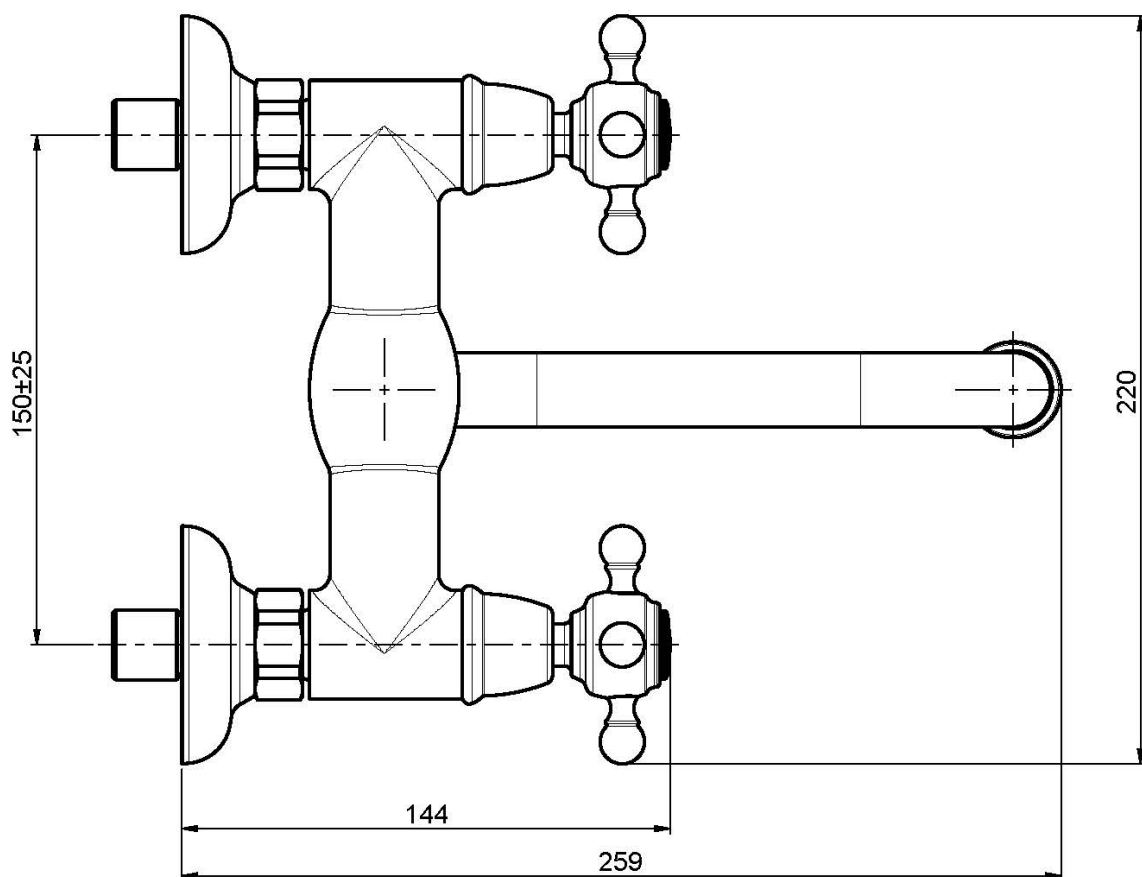
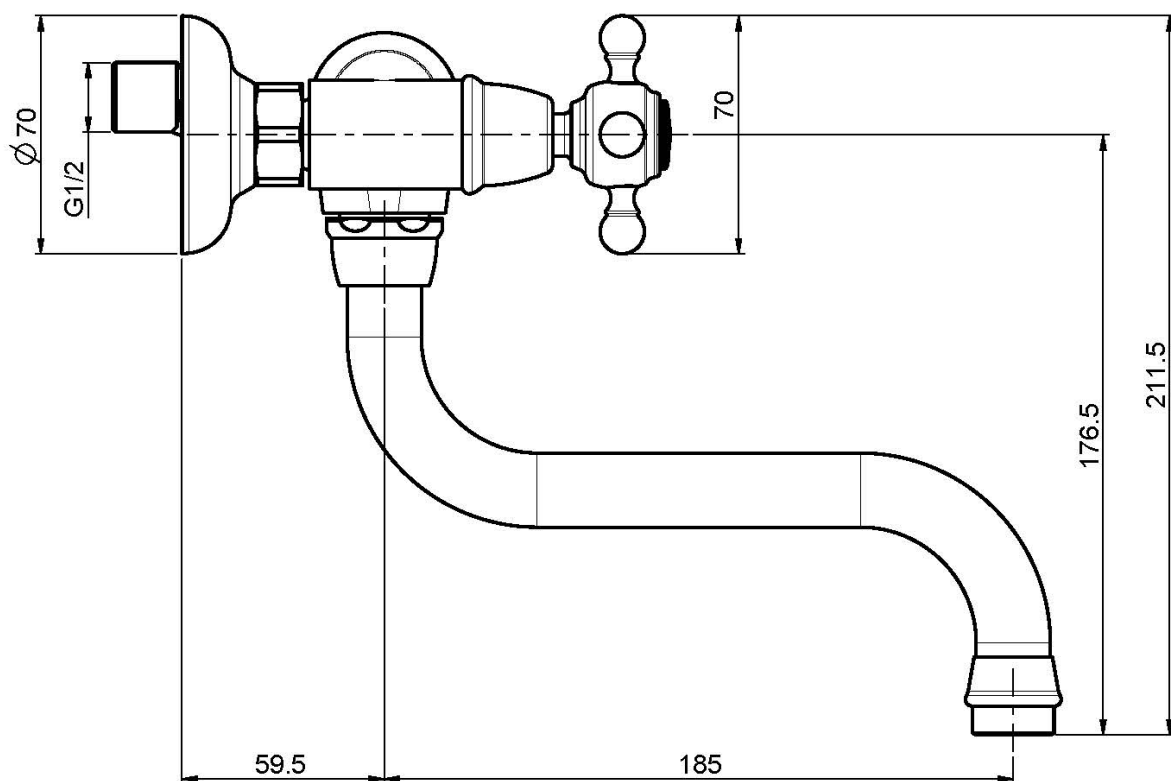

This drawing is the property of FIMA Carlo Frattini. Any complete or partial reproduction, or any transmission to third party without FIMA Carlo Frattini authorization is forbidden.