





Code F7047/1

SPÜLTISCHBATTERIE FLEXI

- n. 2 Flexschläuche
- drehbarer Auslauf
- ABS herausziehbare Brause
- schwarzer Feder

Finishes

-  CHROM
CR
-  NICKEL GEBÜRSTET
SN
-  WEISSMATT
BS
-  SCHWARZMATT
NS

BILD



Siehe die allgemeinen Verkaufsbedingungen auf unserer
geltenden Preisliste

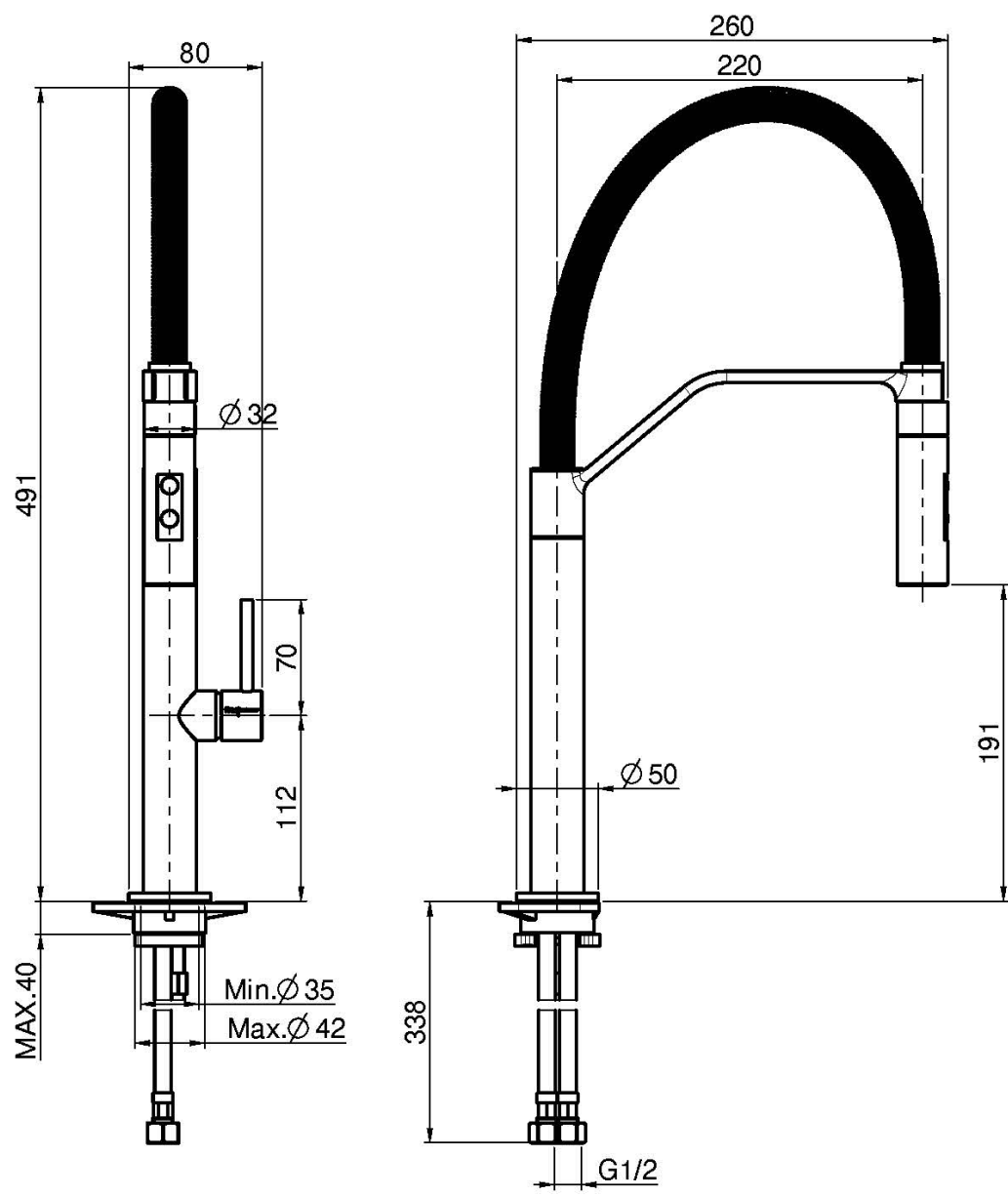

This drawing is the property of FIMA Carlo Frattini. Any complete or partial reproduction, or any transmission to third party without FIMA Carlo Frattini authorization is forbidden.