

Codigo F5614/1

BATERÍA ENCIMERA PARA BAÑERA



• EMBELLECEDOR A PEDIR POR SEPARADO

- flexible nylon 1500 mm
- soporte ducha
- ducha con boquillas anti-cal
- desviador

IMAGEN



Textura

-  H COLLECTION
-  V COLLECTION
-  X COLLECTION

Acabados

-  CROMADO
CR
-  HL
-  HS
-  ZL
-  ZS
-  NÍQUEL SATINADO
SN
-  CROMO NEGRO
CN
-  CROMO NEGRO SATINADO
CS
-  BLANCO MATE
BS
-  NEGRO MATE
NS
-  DORADO
OR
-  ORO SATINADO
OS

LOS PRODUCTOS DEBEN SER PEDIDOS
POR SEPARADO

[C3](#)



[Placa en acero
inox](#)



Consulte las condiciones generales de venta en nuestra lista
de precios aplicable

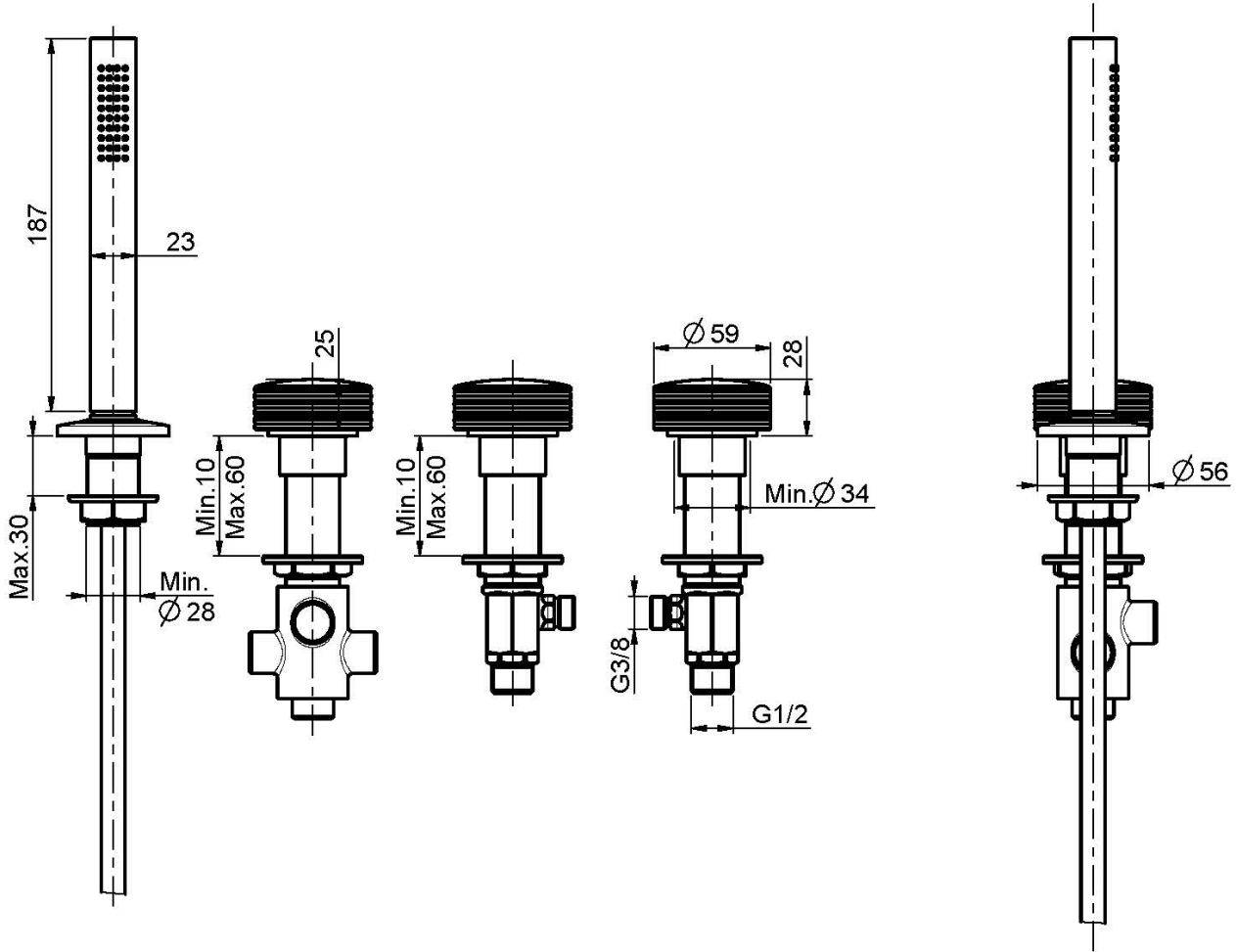

This drawing is the property of FIMA Carlo Frattini. Any complete or partial reproduction, or any transmission to third party without FIMA Carlo Frattini authorization is forbidden.

